

Technical Information

PHOCAS RESTRICTED FRICTION STAYS - DIMENSIONS

DIMENSIONS - MM														
	SIZE	A	B	C	D	E	F	G	H	J	K (13/17mm)	L (13/17mm)	M (13/17mm)	N (13/17mm)
LONG REACH	12"	23	104.5	190.5	15.5	10	13/17	60	75	40.5	24.5/11.5	209.5/115.0	118/101.5	76.5
	16"	23	106	300.5	15.5	10	13/17	60	75	40.5	73.0/11.5	207.5/182.0	257/168.5	100/61.5
STANDARD REACH	12"	26.5	95	173	15.5	-	13/17	46	47	40.5	24.5	196/126	181.5/111.5	-
	16"	26.5	95	305	15.5	-	13/17	48	59	40.5	95/79.5	131/141	-/126.5	-

The position of the friction stay in any given profile will determine whether a standard or long reach stay will be required. Please see guide on page 41 for more information.

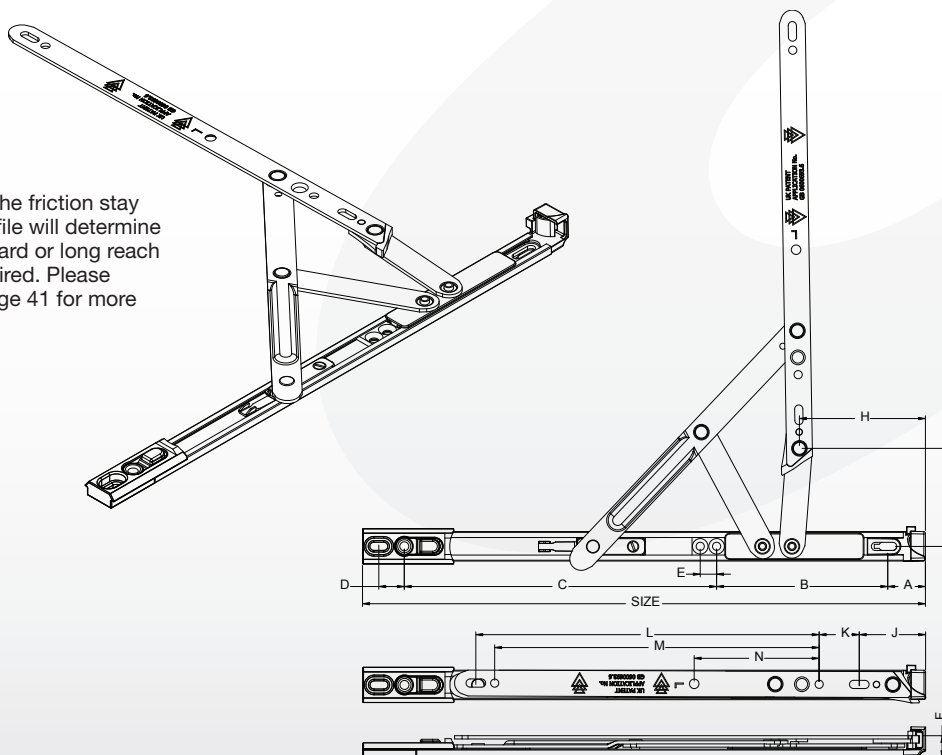

PRODUCT OPTIONS

STYLE	PART NO.	STACK HEIGHT		SIZE	OPEN ANGLE (°)	MAX WEIGHT (KG)	MAX VENT SIZE (MM) W X H	BOX QTY	
		13mm	17mm						
RESTRICTED	LONG REACH	ARESH12P	☺		12	90	22	600 X 1200	40
		ARESH16P	☺		16	90	24	650 X 1200	20
		AHRESH12P		☺	12	90	22	600 X 1200	40
		AHRESH16P		☺	16	90	24	650 X 1200	20
	STANDARD	TARESH12P	☺		12	90	22	600 X 1200	40
		TARESH16P	☺		16	90	24	650 X 1200	20
		TAHRESH12P		☺	12	90	22	600 X 1200	40
		TAHRESH16P		☺	16	90	24	650 X 1200	20



- Tamper proof easy open button to release stay up to 90° from the 100mm restricted position
- Lifetime Guarantee*
- Uniquely fitted end cap with an active compression spring to give the ultimate seal every time the window is used offering trouble free installation
- Manufactured from high quality (430) stainless steel
- 13 & 17mm variants suitable for all popular profiles
- Supplied in standard and long reach variants to suit all uPVC profiles (see page 41 for profile information)

Technical Information

Assessment Data

Performance: cycle tested to over 25,000 operations and tested to BS 6375 Pt.1:2004 & Pt 2:1987

Corrosion resistance: meets requirements of BS EN 1670:1998 grade 4

Restrictor: meets requirements of BS 6375 Part 2 (force against restricted object), tested with one restricted and one standard egress Phocas friction stay

Material Specifications

Track, link and rivets: 430 grade stainless steel (ref BS1449 Part 2:1991)

Metal End Cap: Zinc BS1004A

Plastic Components: Glass reinforced Nylon

Additional Information

Box Quantity: See chart overleaf

Accessories: Hinge Jigs (page 40), Anti-Jemmy & Child Restrictor (see page 43)

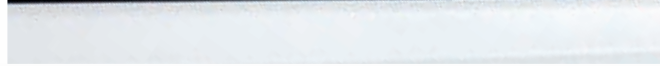

With its Active Compression Technology (ACT), the new Phocas friction stay ensures accurate installation and realignment of the sash and frame, to create the perfect seal with peace of mind and ease of fabrication.



Introducing the new quick-release restrictor mechanism for up to 90° opening.

*Applicable to the life of the installed window and subject to Avocet's mechanical warranty and maintenance instructions.

