

Technical Information

PHOCAS EASY CLEAN FRICTION STAY - DIMENSIONS

DIMENSIONS - MM

	SIZE	A	B	C	D	E	F	G	H	J	K (13/17mm)	L (13/17mm)	M (13/17mm)	N (13/17mm)
LONG REACH	12"	23.0	17.5	262.0	16.0	13/17	60.0	75.0	147.0	40.5	24.5/11.5	209.5/115.0	198.0/101.5	76.5/N/A
	16"	23.0	17.5	373.0	16.0	13/17	60.0	75.0	289.0	40.5	73.0/11.5	115.0/207.5	101.5/257.0	100.0/61.5
STANDARD REACH	12"	23.0	17.5	269.0	16.0	13/17	46.0	48.0	127.0	40.5	24.5	196.8/126.0	181.5/111.5	N/A
	16"	23.0	17.5	369.5	16.0	13/17	48.0	58	275	40.5	98.0/79.5	131.0/141.0	126.5	N/A

The position of the friction stay in any given profile will determine whether a standard or long reach stay will be required. Please see guide on page 41 for more information.

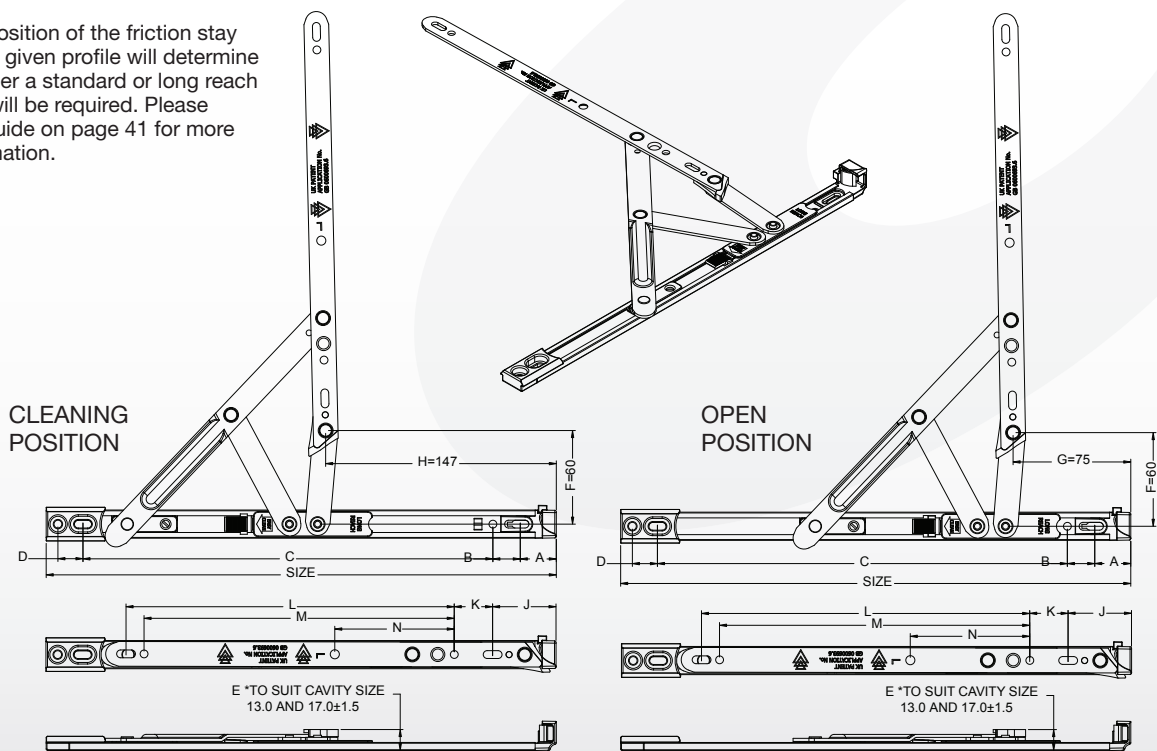

PRODUCT CODES

STYLE	PART NO.	STACK HEIGHT		SIZE	OPEN ANGLE (°)	MAX WEIGHT (KG)	MAX VENT SIZE (MM) W X H	BOX QTY	
		13mm	17mm						
EGRESS EASY CLEAN	LONG REACH	AECSH12P-40	⌚		12	90	22	600 X 1200	40
		AECSH16P-20	⌚		16	90	24	650 X 1200	20
	STANDARD	AHECSH12P-40		⌚	12	90	22	600 X 1200	40
		AHECSH16P-20		⌚	16	90	24	650 X 1200	20
EGRESS EASY CLEAN	LONG REACH	TAECSH12P	⌚		12	90	22	600 X 1200	40
		TAECSH16P	⌚		16	90	24	650 X 1200	20
	STANDARD	TAHECSH12P		⌚	12	90	22	600 X 1200	40
		TAHECSH16P		⌚	16	90	24	650 X 1200	20



- A NEW range of easy clean/egress side hung variants
- Lifetime Guarantee*
- 90° opening egress facility
- Easy clean function with press to release button which automatically re-engages to the normal operating position when window is closed using the window handle
- Uniquely fitted end cap with an active compression spring to give the ultimate seal every time the window is used offering trouble free installation
- 13 & 17mm stack heights suitable for all popular profiles
- Supplied in standard and long reach variants to suit all uPVC profiles (see page 41 for profile information)

Technical Information

Assessment Data

Performance: cycle tested to over 25,000 operations and tested to BS 6375 Pt.1:2004 & Pt 2:1987

Corrosion resistance: meets requirements of BS EN 1670:1998 grade 4

Egress: can meet requirements of BS 5588:1998 Pt 1: 1990 & document B of the building regulations, meets requirements of BS 8213 Pt 1:1991

BBA Test Report No: 2812

Material Specifications

Track, link and rivets: 430 grade stainless steel
(ref BS1449 Part 2:1991)

Metal End Cap: Zinc BS1004A

Plastic Components: Glass reinforced Nylon

Additional Information

Box Quantity: See chart overleaf

Accessories: Hinge Jigs (page 40), Anti-Jemmy & Child Restrictor (see page 43)



With its Active Compression Technology (ACT), the new Phocas friction stay ensures accurate installation and realignment of the sash and frame, to create the perfect seal with peace of mind and ease of fabrication.

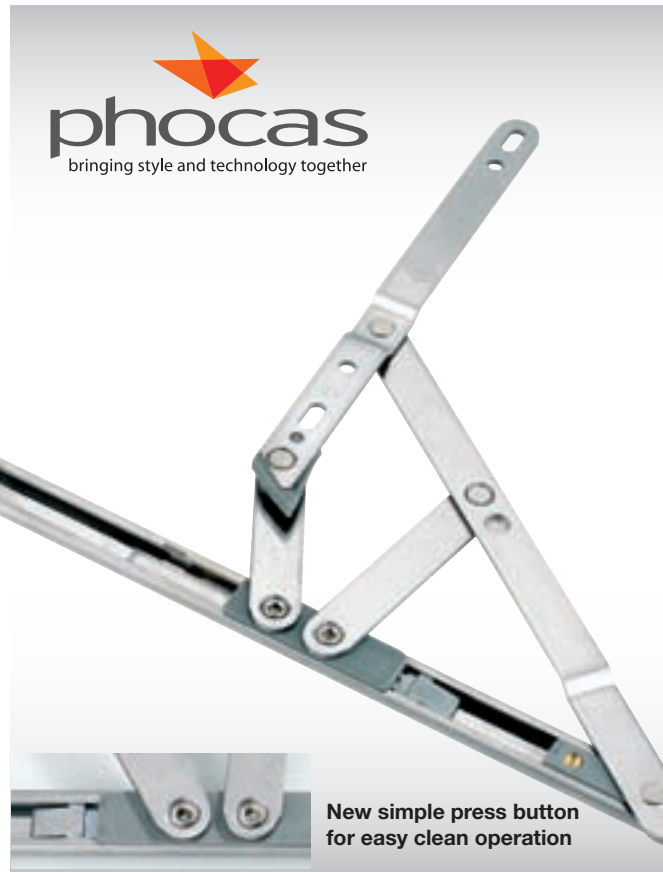

New simple press button for easy clean operation

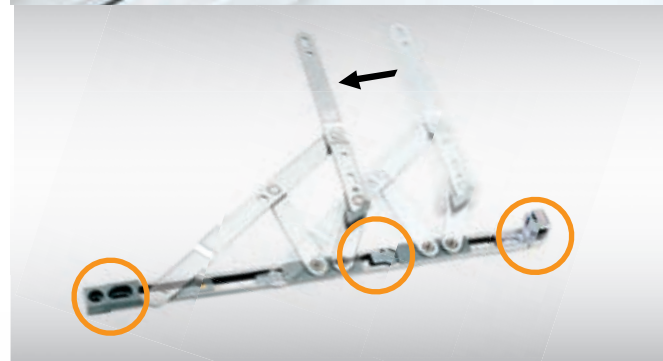

REPORT NO: 2812

*Applicable to the life of the installed window and subject to Avocet's mechanical warranty and maintenance instructions.