

## Technical Information

### PHOCAS FRICTION STAY - DIMENSIONS

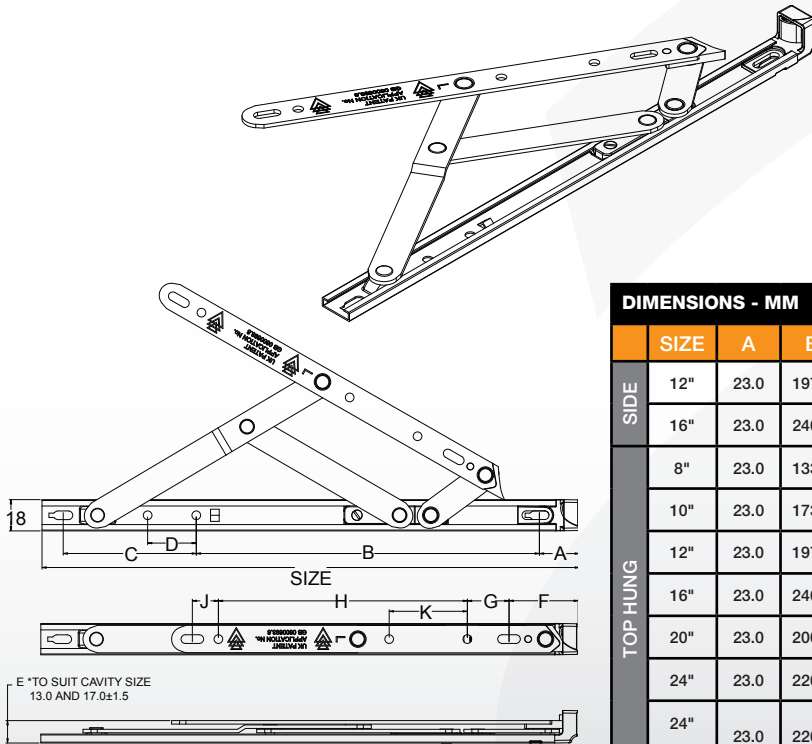

#### DIMENSIONS - MM

	SIZE	A	B	C	D	E	F	G	H	J	K
SIDE	12"	23.0	197.5	76.5	76.5	13/17	40.0	59.0	108.5	15.0	-
	16"	23.0	240.5	134.0	66.5	13/17	40.0	24.0	198.0	24.0	94.5
TOP HUNG	8"	23.0	133.5	42.0	-	13/17	41.5	12.0	95.5	15.0	-
	10"	23.0	173.5	52.0	-	13/17	41.0	24.0	112.5	15.0	-
	12"	23.0	197.5	76.5	28.0	13/17	40.0	24.0	143.5	15.0	45.0
	16"	23.0	240.5	134.5	66.5	13/17	40.0	24.0	198.0	24.0	94.5
	20"	23.0	200.5	274.5	136.5	13/17	40.0	24.0	246.0	24.0	128.0
	24"	23.0	220.5	354.5	166.5	13/17	40.0	24.0	189.0	131.0	-
	24" HD	23.0	220.5	354.5	166.5	13/17	40.0	24.0	189.0	131.0	95.0

### PRODUCT CODES

	PART NO.	STACK HEIGHT		SIZE	OPEN ANGLE (°)	MAX WEIGHT (KG)	MAX VENT SIZE (MM) W X H	BOX QTY
		13mm	17mm					
SIDE HUNG	ASH12P	⊙		12	60	22	600 X 1200	50
	AHSH12P		⊙	12	60	22	600 X 1200	40
	ASH16P	⊙		16	60	24	650 X 1200	25
	AHSH16P		⊙	16	60	24	650 X 1200	20
TOP HUNG	ATH08P	⊙		8	60	12	1200 X 350	50
	AHTH08P		⊙	8	60	12	1200 X 350	40
	ATH10P	⊙		10	70	14	1200 X 400	50
	AHTH10P		⊙	10	70	14	1200 X 400	40
	ATH12P	⊙		12	60	16	1200 X 550	50
	AHTH12P		⊙	12	60	16	1200 X 550	40
	ATH16P	⊙		16	60	20	1200 X 800	25
	AHTH16P		⊙	16	60	20	1200 X 800	20
	ATH20P	⊙		20	40	24	1200 X 900	25
	AHTH20P		⊙	20	40	24	1200 X 900	20
	ATH24P	⊙		24	40	27	1200 X 1000	25
	AHTH24P		⊙	24	40	27	1200 X 1000	20
	ATH24PHD	⊙		24	40	35	1200 X 1200	25
	AHTH24PHD		⊙	24	40	35	1200 X 1200	20



- A complete range of top & side hung variants
- Lifetime Guarantee\*
- Uniquely fitted end cap with an active compression spring to give the ultimate seal every time the window is used offering trouble free installation
- BBA Approved
- 13 & 17mm stack heights suitable for all popular profiles

## Technical Information

### Assessment Data

**Performance:** cycle tested to over 25,000 operations and tested to BS 6375 Pt.1:2004 & Pt 2:1987

**Corrosion resistance:** meets requirements of BS EN 1670:1998 grade 5

**BBA Test Report No: 2812**

### Material Specifications

**Track, link and rivets:** 430 grade stainless steel (ref BS1449 Part 2:1991)

**Metal End Cap:** Zinc BS1004A

**Plastic Components:** Glass reinforced Nylon

### Additional Information

**Box Quantity:** See chart overleaf

**Accessories:** Hinge Jigs (page 40), Anti-Jemmy & Child Restrictor (see page 43)

**Also available in narrow track format on request**



PICTURE SHOWS HIGH STACK VARIANT



PICTURE SHOWS 14mm NARROW TRACK VARIANT. IDEAL FOR SLIM ALUMINIUM WINDOW PROFILE



With its Active Compression Technology (ACT), the new Phocas friction stay ensures accurate installation and realignment of the sash and frame, to create the perfect seal with peace of mind and ease of fabrication.

\*Applicable to the life of the installed window and subject to Avocet's mechanical warranty and maintenance instructions.



REPORT NO: 2812

Call our Sales Team now on 01484 725 001

**avocet**  
HARDWARE